



MODEL NUMBER

SERIAL NUMBER

MOTOR MODEL NUMBER

MOTOR SERIAL NUMBER



(This page intentionally left blank)



TABLE OF CONTENTS

| | |
|---------------------------------|----|
| LIMITED WARRANTY | 4 |
| DESIGN CHANGES | 5 |
| SAFETY | 6 |
| ELECTRICAL..... | 7 |
| CONVEYOR OPERATION | 8 |
| MAINTENANCE..... | 9 |
| BEARINGS | 9 |
| BELT | 9 |
| BELT REPLACEMENT | 10 |
| BELT TENSION AND TRACKING | 11 |
| GENERAL | 12 |
| PARTS LIST | 13 |
| TENSION END COMPONENTS | 14 |
| DRIVE END COMPONENTS | 15 |
| MISC. COMPONENTS | 16 |
| GENERAL INFORMATION | 17 |



LIMITED WARRANTY

Pax Products Inc. (the "Company") warrants to the original purchaser of each Pax Conveyor that the conveyor will be free from defects in material and workmanship, under normal and proper installation, use and maintenance in accordance with the Company's instructions, for a period of 90 days after the date of shipment from the Company's plant.

Purchaser's exclusive remedy and the Company's sole liability under the above warranty or in connection with any other claim relating to the Pax Conveyor shall be limited to repair, or at the Company's option, the replacement or refund of the purchase price, of any Conveyor or part or component thereof which is returned to the Company freight prepaid and which is defective in material or workmanship. Defective Conveyors or parts or components thereof which the Company replaces become the property of the company. All Conveyors or parts or components thereof which are returned to the purchaser will be returned freight collect.

EXCEPT AS EXPRESSLY STATED ABOVE, THE COMPANY MAKES NO WARRANTY, EXPRESSED OR IMPLIED, WHETHER OF MERCHANTABILITY OR FITNESS FOR ANY PARTICULAR PURPOSE OR USE OR OTHERWISE ON ANY CONVEYOR OR ANY PARTS OR LABOR FURNISHED DURING THE SALE, DELIVERY, OR SERVICING OF ANY CONVEYOR.

IN NO EVENT SHALL THE COMPANY BE LIABLE TO ANY PURCHASER OR PERSON CLAIMING THROUGH ANY PURCHASER FOR ANY SPECIAL, INDIRECT, INCIDENTAL, OR CONSEQUENTIAL DAMAGES ARISING OUT OF, OR AS A RESULT OF THE SALE, DELIVERY, NONDELIVERY, SERVICING, USE, OR LOSS OF USE OF ANY PAX CONVEYOR OR PART THEREOF OR FOR ANY CHARGES OR EXPENSES OF ANY NATURE INCURRED WITHOUT THE COMPANY'S WRITTEN CONSENT EVEN THOUGH THE COMPANY HAS BEEN NEGLIGENT. IN NO EVENT SHALL THE COMPANY'S LIABILITY UNDER ANY CLAIM MADE BY ANY PURCHASER OR PERSON CLAIMING THROUGH ANY PURCHASER EXCEED THE PURCHASE PRICE OF THE PAX CONVEYOR OR PART OF COMPONENT THEREOF IN RESPECT OF WHICH DAMAGES ARE CLAIMED.

Purchaser shall promptly inspect each conveyor upon receipt. Claims under the above warranty shall be made by contacting the Company at P.O. Box 257, 5097 Monroe Rd. Celina, OH 45822. Attn: Service Department (1-800-733-6930) or (419) 586-6948. No claim under the above warranty will be allowed unless made 10 days after the date of the warranty period on which the defect is or should have been discovered by the purchaser.



DESIGN CHANGES

Consistent with sound engineering principals and recognized practices, Pax Products Inc. reserves the right to discontinue or change specifications, designs, and materials at any time without notice.

Design differences or changes that exist between the conveyor received and the conveyor illustrated in the manual are the result of design improvements or special arrangements contracted for at the time of purchase. Every effort is made to keep the manual consistent with the majority of the systems supplied.



SAFETY

UNDER NO CIRCUMSTANCES SHOULD THE PAX CONVEYOR OR ANY COMPONENT BE PLACED IN SUCH A MANNER THAT COULD CAUSE POSSIBLE PERSONAL INJURY OR DAMAGE TO EQUIPMENT OR PERSONNEL.

PERSONNEL SHOULD BE ALERTED TO THE POTENTIAL HAZARD OF ENTANGLEMENT IN CONVEYOR CAUSED BY ITEMS SUCH AS LONG HAIR, LOOSE CLOTHING, JEWELRY, AND ETC.

DUE TO POSSIBLE REMOTE CONVEYOR CONTROLS, CONVEYOR MAY START OR STOP WITHOUT WARNING.

A CONVEYOR WHICH WOULD CAUSE INJURY WHEN STARTED SHALL NOT BE STARTED UNTIL EMPLOYEES IN THE AREA ARE ALERTED BY A SIGNAL OR BY A DESIGNATED PERSON THAT THE CONVEYOR IS ABOUT TO START.

WHERE EMPLOYEE SAFETY IS DEPENDENT UPON STOPPING AND/ OR STARTING DEVICES, THEY SHALL BE KEPT FREE OF OBSTRUCTIONS TO PERMIT READY ACCESS

PERSONNEL WORKING ON OR NEAR A PAX CONVEYOR SHALL BE INSTRUCTED AS TO THE LOCATION AND OPERATION OF PERTINENT STOPPING DEVICES.

UNDER NO CIRCUMSTANCES SHALL THE SAFETY CHARACTERISTICS OF THE PAX CONVEYOR BE ALTERED IF SUCH ALTERATIONS WOULD ENDANGER PERSONNEL.

A PAX CONVEYOR SHALL BE USED TO TRANSPORT ONLY MATERIAL IT IS CAPABLE OF HANDLING SAFELY.

THE AREA AROUND LOADING AND UNLOADING POINTS SHALL BE KEPT CLEAR OF OBSTRUCTIONS WHICH COULD ENDANGER PERSONNEL.

ROUTINE INSPECTIONS AND PREVENTIVE AND CORRECTIVE MAINTENANCE PROGRAMS SHALL BE CONDUCTED TO NSURE THAT ALL SAFETY FEATURES AND DEVICES ARE RETAINED AND FUCTION PROPERLY.

MAKE SURE POWER IS DISCONNECTED BEFORE SERVICING, TROUBLESHOOTING OR MOVING ANY PAX CONVEYOR.

CONVEYORS SHOULD BE PLACED SO THAT NO COMPONENT OR COMBINATION OF COMPONENTS INTERFER WITH THE NORMAL OPERATION OF ANY MACHINE.



ELECTRICAL

As standard, each Pax Conveyor comes equipped with a variable frequency drive. If a Pax conveyor is ordered without a variable frequency drive, then the customer is responsible for properly wiring the conveyor into an electrical control. In this case electrical work shall be installed and wired by a qualified electrician and follow all application standards.

Use of a power source other than that listed on the variable frequency drive may cause damage to the Pax conveyor and will void the warranty. The motor is protected by a thermal overload switch. This switch will be wired into the VFD and will shut down the conveyor if the motor overheats. In the case the Pax conveyor was ordered without a VFD and the thermal overload switch was not wired into the electrical controls, the warranty on the motor will be voided.

If the Pax conveyor is not supplied with a VFD then it is the customers responsibility to arrange and locate a VFD so that the operation of the equipment is visible from the operator, and shall be clearly marked or labeled to indicate the function being controlled.

ELECTRICAL CODE: All wiring shall conform to the National Electrical Code (article 670 or other applicable articles) as published by the National Fire Protection Association and approved by the American Standards Institute, Inc.

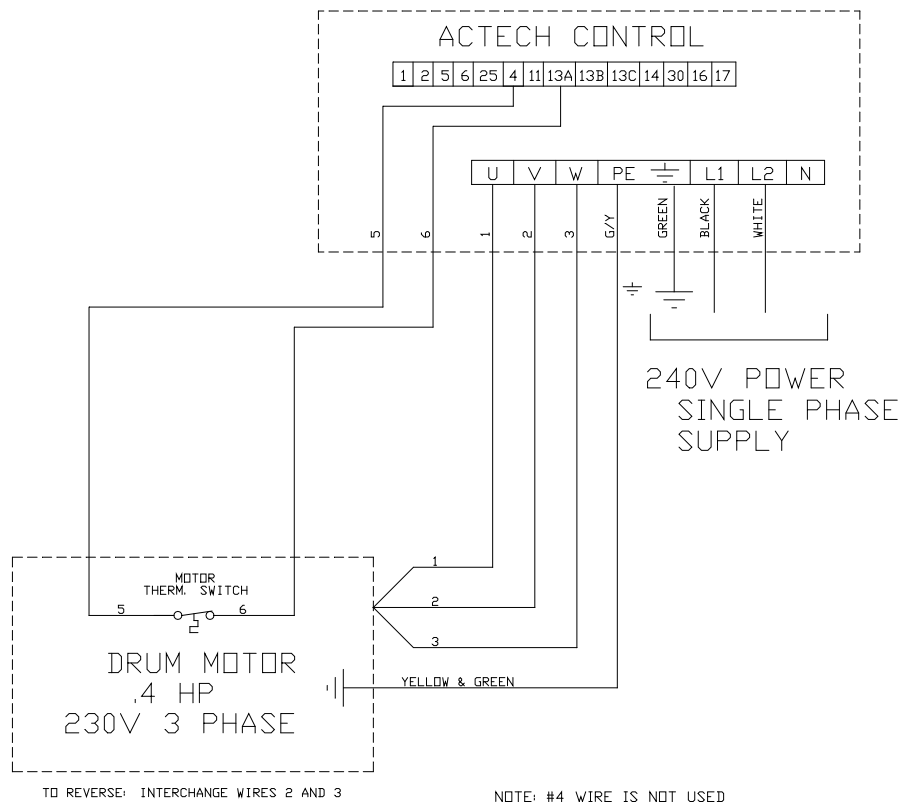

Figure 1.RECOMMENDED WIRING



CONVEYOR OPERATION

The primary function of the Pax Conveyor is to remove material from or away from other equipment. The rugged construction will tolerate the abuse commonly found in the stamping environment. A hermetically sealed motor will withstand the flooding of coolant and is ideal for dirty environment. The standard belt is a 2-ply Urethane rugged enough to handle the constant dropping of parts on the conveyor. This belt has a belt life 2 to 4 times greater than typical conveyors.

The standard Pax conveyor can move material in either direction. Siderails can easily be adapted to suit any height. Other customizable options include a magnetic bed, adjustable legs on casters, and diverters.



MAINTENANCE

- It is important that a maintenance program be established to ensure that all conveyor components are maintained in a condition which does not constitute a hazard to personnel.
- When a conveyor is stopped for maintenance purposes, starting devices or powered accessories shall be locked and tagged out in accordance with a formalized procedure designed to protect all person or groups involved with the conveyor against an unexpected start.
- Replace all safety devices and guards before starting equipment for normal operation.

BEARINGS

Pax conveyors use maintenance free tension end bearings to provide smooth operation of rotating components.

In the event that the tension end stub shafts require replacement, remove the old stub shaft by machining or grinding the weld away. Inspect the tension pulley bore to verify that the diameter is in the range of 0.499" to 0.503". Remove any remaining weld from the cylinder face.

Remove oil and debris before inserting new stub shaft (410-4146-0). Seat the stub shaft flush with the cylinder face and weld a continuous 1/8" fillet weld around the stub shaft. The weld should be performed using Gas Tungsten Arc Welding with ER70S filler wire or equivalent. The weld joint should be allowed to air cool.

BELT

The belt should routinely be cleaned and inspected for signs of wear. The lacing and connecting pin should also be checked for defects such as the laces separating from the belt. The most effective routine is to inspect the conveyor after every use.

If the belt is torn, cracked, or otherwise deteriorated, it should be replaced immediately with a new belt.

The tracking should be checked and adjusted as needed. Procedures for changing the belt and adjusting the tracking and tension are detailed in proceeding sections.



BELT REPLACEMENT

The Pax Conveyor was designed for quick belt replacement. The following procedures should be followed in the sequence listed:

- 1) Stop the conveyor so that the laces and connecting pin in the belt are in a position where the pin can be removed easily.
- 2) Disconnect the power to the conveyor. An electrical Lockout/Tagout device is recommended.
- 3) Using a 3/8" wrench; relieve belt tension by turning the tension adjustment screws (Item 7, Figure 3) clockwise.
- 4) Using a 3/8" wrench; remove the (6) screws that fasten the drive pulley cover. Remove the motor cover (Item 5, Figure 4).
- 5) Use a needle nose pliers to pull the connecting pin out of the conveyor belt laces.
- 6) Grab the belt behind the drive pulley and pull the belt out of the conveyor.
- 7) Insert one end of new belt under the drive pulley and over the idler pulley. Pull belt under the tray all the way past the tension end pulley. Then lay the rest of the belt on top of the conveyor tray. Make sure edges of the belt are aligned and the two belt ends are together so the laces interlock. Slide the connecting rod through the side slot and through the laces. Ensure the connecting rod is centered on the laces.
- 8) Replace the drive pulley cover and secure.
- 9) Continue to next page for belt tension and tracking adjustment.



BELT TENSION AND TRACKING

Proper belt tension and tracking are key elements for efficient performance of the Pax Conveyor. Too much tension may cause damage to the motor, belt, bearings, etc. Too little tension may cause the belt to slip when it is not supposed to slip. Improper tracking may cause excessive belt wear and/or possible belt stretch.

The following steps need to be followed in sequence to ensure proper adjustment of belt tension and tracking:

- 1) Loosen the tension screws (Item 7, Figure 3) evenly until there is little or no tension on the belt.
- 2) Make sure the conveyor is clear to operate and turn on the conveyor motor. Tighten the tension screws, by turning them counter-clockwise, until the belt moves smoothly.
- 3) Visually check the belt tracking by viewing the belt during operation. Look along the edge of the belt. The belt should travel near the center of the tray.
- 4) If the belt appears to be running against one side of the tray more than the other, tighten the tension screw on the side the belt is rubbing against and loosen the opposite side an equal amount. Continue tightening and loosening until the belt is centered and belt is running flat.



GENERAL

The Pax Conveyor should routinely be cleaned and inspected for wear or damage. A routine inspection should cover the following:

- 1) Make sure the power cord has no exposed wires or visible signs of damage to the cord. Inspect the plug and where the cord connects to the motor for damage.
- 2) Make sure all the fasteners are tight. Since conveyors are used in high vibration environments, a fastener may vibrate loose. Use caution not to overtighten bolts that are threaded into aluminum.
- 3) Ensure the motor cover is in good working order and securely fastened in place. This protective cover must remain in place at all times during operation.
- 4) Clean the conveyor using a solvent or mild soap and water. Do not use abrasive cleaners or harsh chemicals such as acids or strong bases.
- 5) Inspect the belt for wear, tracking, and proper tension.
- 6) Inspect the tray for dents or damage that may impede performance of the conveyor. If necessary, replace the tray and/or polyethylene strip to insure proper performance.



PARTS LIST

ORDER REPAIR AND REPLACEMENT PARTS FROM:

PAX PRODUCTS INC.
P.O. BOX 257
5097 MONROE RD.
CELINA, OHIO 45822
1-800-733-6930 PHONE
(419) 586-6948 PHONE
(419) 586-6932 FAX

PLEASE PROVIDE THE MODEL NUMBER AND SERIAL NUMBER WHEN ORDERING

NOTE: SUBSTITUTING PARTS NOT AUTHORIZED BY PAX PRODUCTS, INC. MAY CAUSE A DETERIORATED PERFORMANCE OF THE CONVEYOR AND WILL VOID WARRANTY.

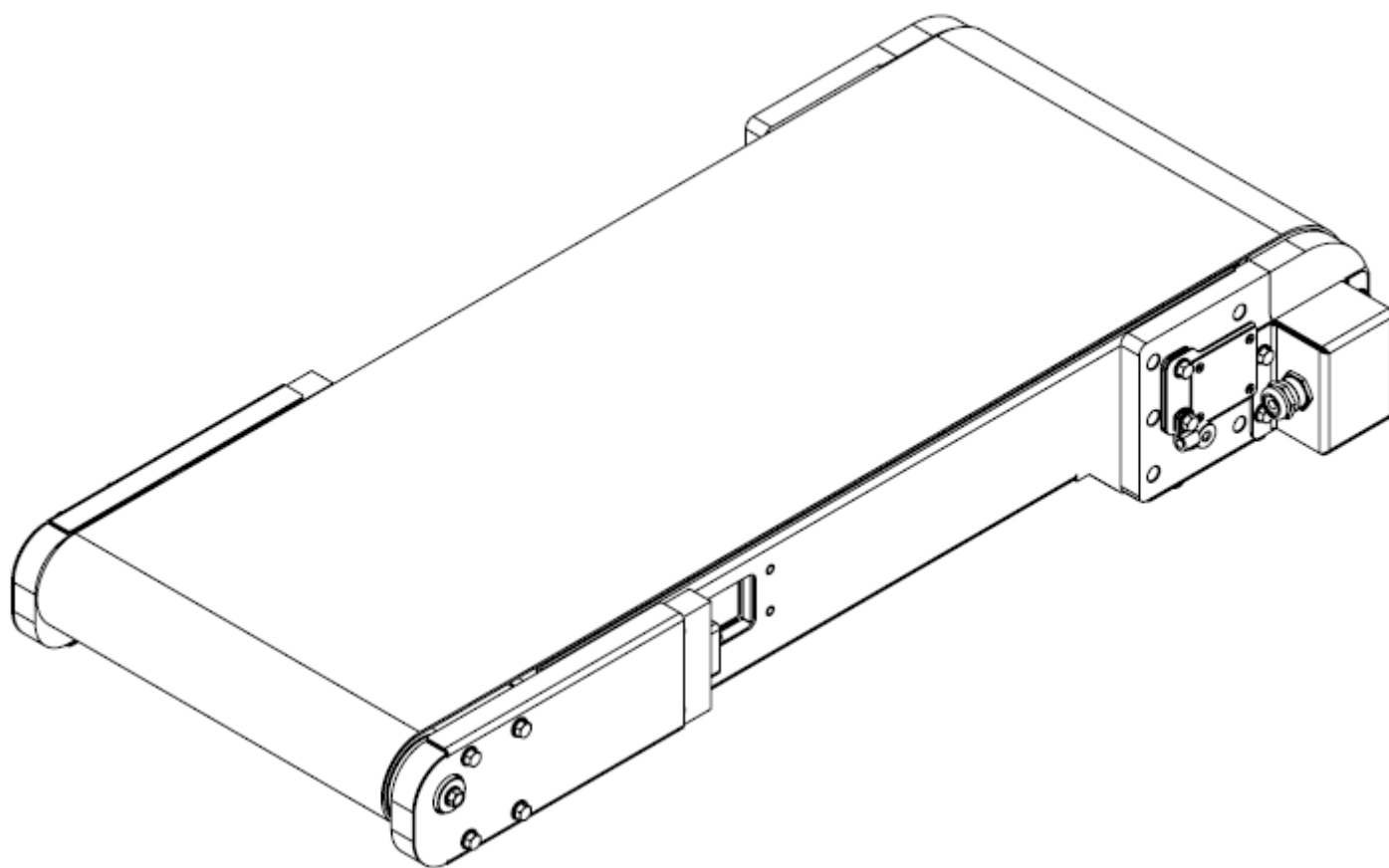

Figure 2. GENERAL ASSEMBLY



TENSION END COMPONENTS

| <u>ITEM NO.</u> | <u>PART NUMBER</u> | <u>DESCRIPTION</u> | <u>QTY.</u> |
|-----------------|--------------------|---|-------------|
| 1 | (CALL FACTORY) | TENSION PULLEY | 1 |
| 2 | 410-4146-0 | TENSION PULLEY STUB SHAFT | 2 |
| 3 | 410-4135-1 | DMC RH 2.5" TENSION END BEARING HOUSING | 1 |
| 4 | 230-10310-0 | HFH 1/4"-20 X 1/2" | 8 |
| 5 | 410-4159-0 | TENSION END COVER RH | 1 |
| 6 | 410-4133-0 | DMC 2.5" TENSION MNT PLATE | 2 |
| 7 | 410-4143-0 | TENSION PULLEY ADJUSTMENT ASSEMBLY | 2 |
| 8 | 410-4128-0 | DMC RETAINING NUT | 2 |
| 9 | EGD-000-6714-0 | SHCS #10-32 X 1/2" | 2 |
| 10 | 500-5619-0 | SHCS 1/4"-20 X 5/8" | 2 |
| 11 | 410-4136-0 | DMC 2.5" TENSION SLIDE BAR | 2 |
| 12 | EGD-000-6628-0 | SELF-ALIGNING BEARING 2203 | 2 |
| 13 | 410-4158-0 | TENSION END COVER LH | 1 |
| 14 | 230-10308-0 | HFH 1/4"-20 X 3/4" | 2 |
| 15 | EGD-000-6314-0 | HEAVY WASHER - 1-4" CLEARANCE | 2 |
| 16 | 410-4134-1 | DMC LH 2.5" TENSION END BEARING HOUSING | 1 |

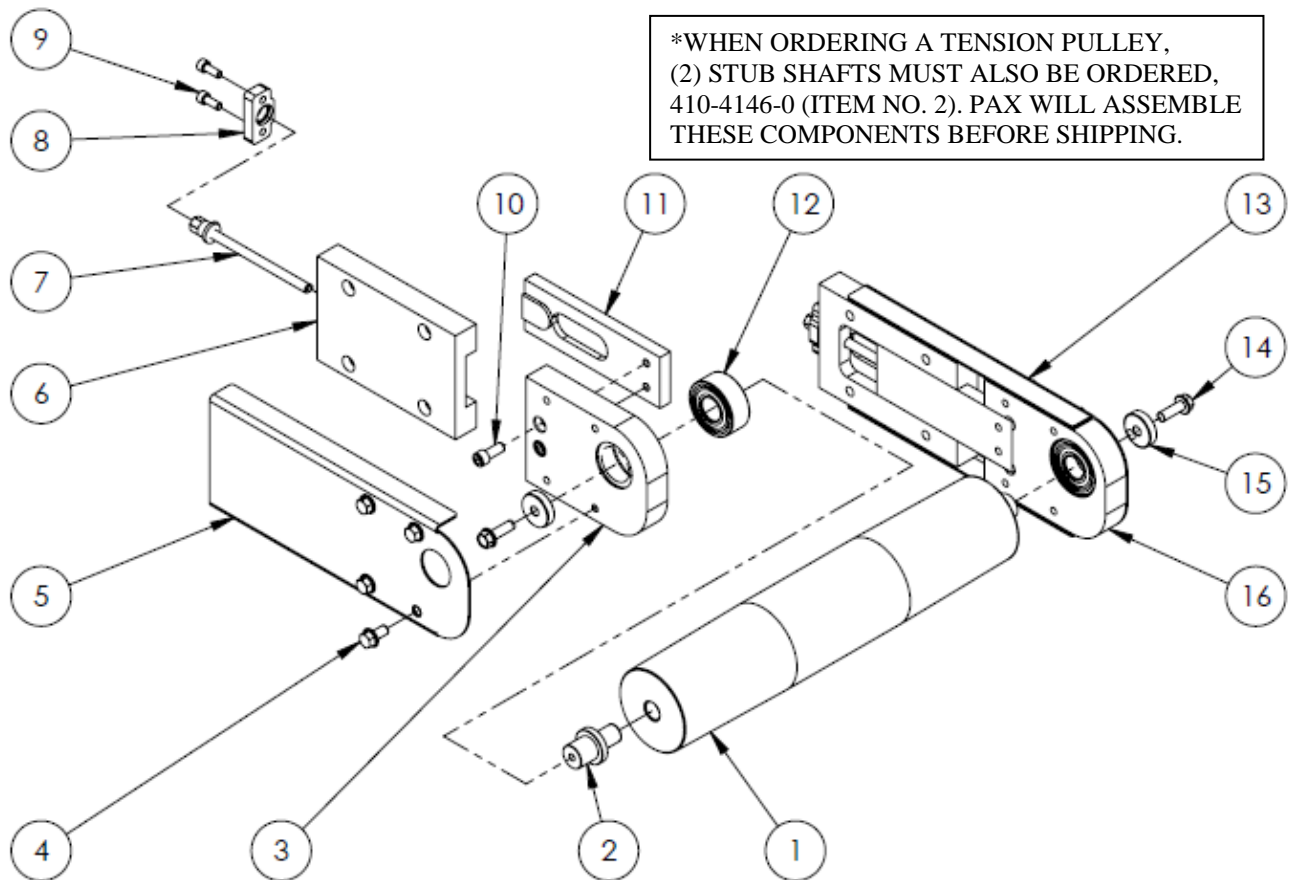

Figure 3. TENSION END COMPONENTS

DRIVE END COMPONENTS

| <u>ITEM NO.</u> | <u>PART NUMBER</u> | <u>DESCRIPTION</u> | <u>QTY.</u> |
|-----------------|--------------------|---------------------------|-------------|
| 1 | (CALL FACTORY) | DRUM MOTOR | 1 |
| 2 | 410-4109-1 | MOTOR RETAINING CAP - DMC | 2 |
| 3 | 410-4108-1 | R.H. MOTOR SIDEPLATE | 1 |
| 4 | (CALL FACTORY) | IDLER PULLEY | 1 |
| 5 | (CALL FACTORY) | MOTOR COVER | 1 |
| 6 | 230-10310-0 | HFH 1/4"-20 X 1/2" | 12 |
| 7 | EGD-125-6307-0 | OUTPUT SHAFT CAP | 1 |
| 8 | EGD-000-6703-0 | FHCS 1/4"-20 x 3/4" | 1 |
| 9 | 430-4106-0 | SHCS 5/16"-18 X 3" | 4 |
| 10 | 500-5733-0 | CORD CONNECTOR | 1 |
| 11 | 410-4117-0 | BEARING COVER | 2 |
| 12 | 220-10094-0 | #4 LOOP | 1 |
| 13 | EGD-000-6715-0 | POP RIVET 1/8" DIA | 4 |
| 14 | 500-5614-0 | MODEL/SERIAL NUMBER TAG | 1 |
| 15 | 410-4150-0 | SERIAL NUMBER PLATE | 1 |
| 16 | 410-4154-0 | MOTOR JUNCTION BOX | 1 |
| 17 | 410-4107-1 | L.H. MOTOR SIDEPLATE | 1 |
| 18 | EGD-000-6602-0 | BALL BEARING 6203-2RS | 2 |
| 19 | EGD-125-6313-0 | ROCKER ARM STUB SHAFT | 2 |

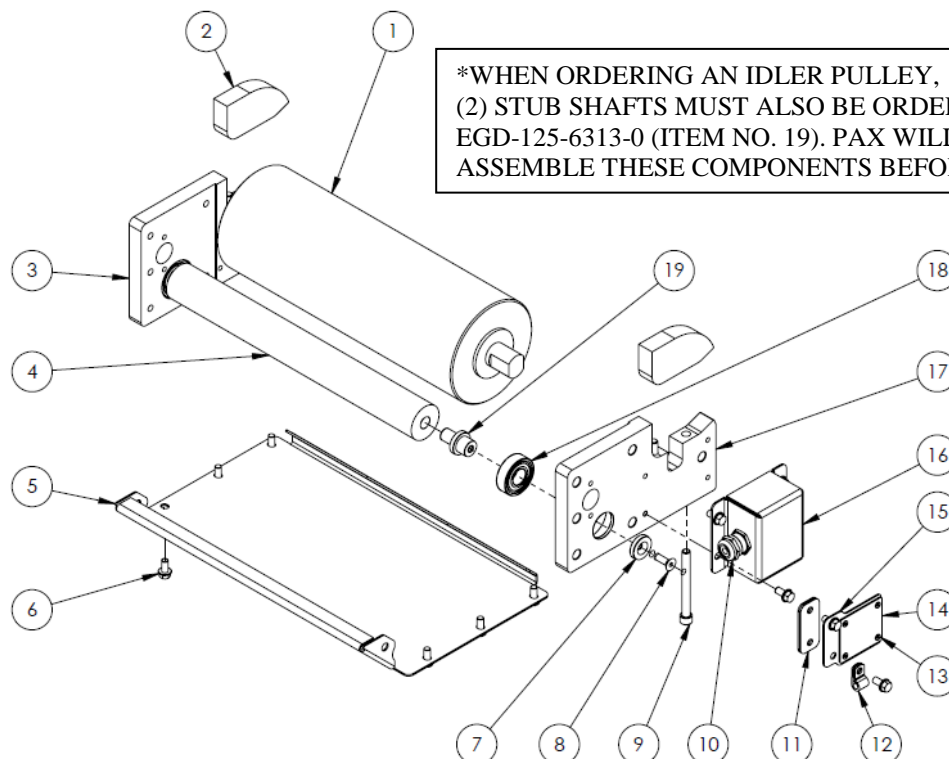

Figure 4. DRIVE END COMPONENTS



MISC. COMPONENTS

| <u>ITEM NO.</u> | <u>PART NUMBER</u> | <u>DESCRIPTION</u> | <u>QTY.</u> |
|-----------------|--------------------|--------------------------------------|-------------|
| 1 | (CALL FACTORY) | BELT | 1 |
| 2 | 500-5624-0 | FPCS #6-32 X 1/4" BRASS | * |
| 3 | (CALL FACTORY) | POLYETHYLENE STRIP HOLD DOWN BRACKET | 1 |
| 4 | (SEE FIGURE 3) | TENSION END COMPONENTS | 1 |
| 5 | (CALL FACTORY) | VFD CONTROL | 1 |
| 6 | (CALL FACTORY) | TRAY | 1 |
| 7 | (CALL FACTORY) | PROTECTIVE POLYETHYLENE STRIP | 1 |
| 8 | (SEE FIGURE 4) | DRIVE END COMPONENTS | 1 |

* QUANTITY IS DEPENDENT ON SIZE OF CONVEYOR

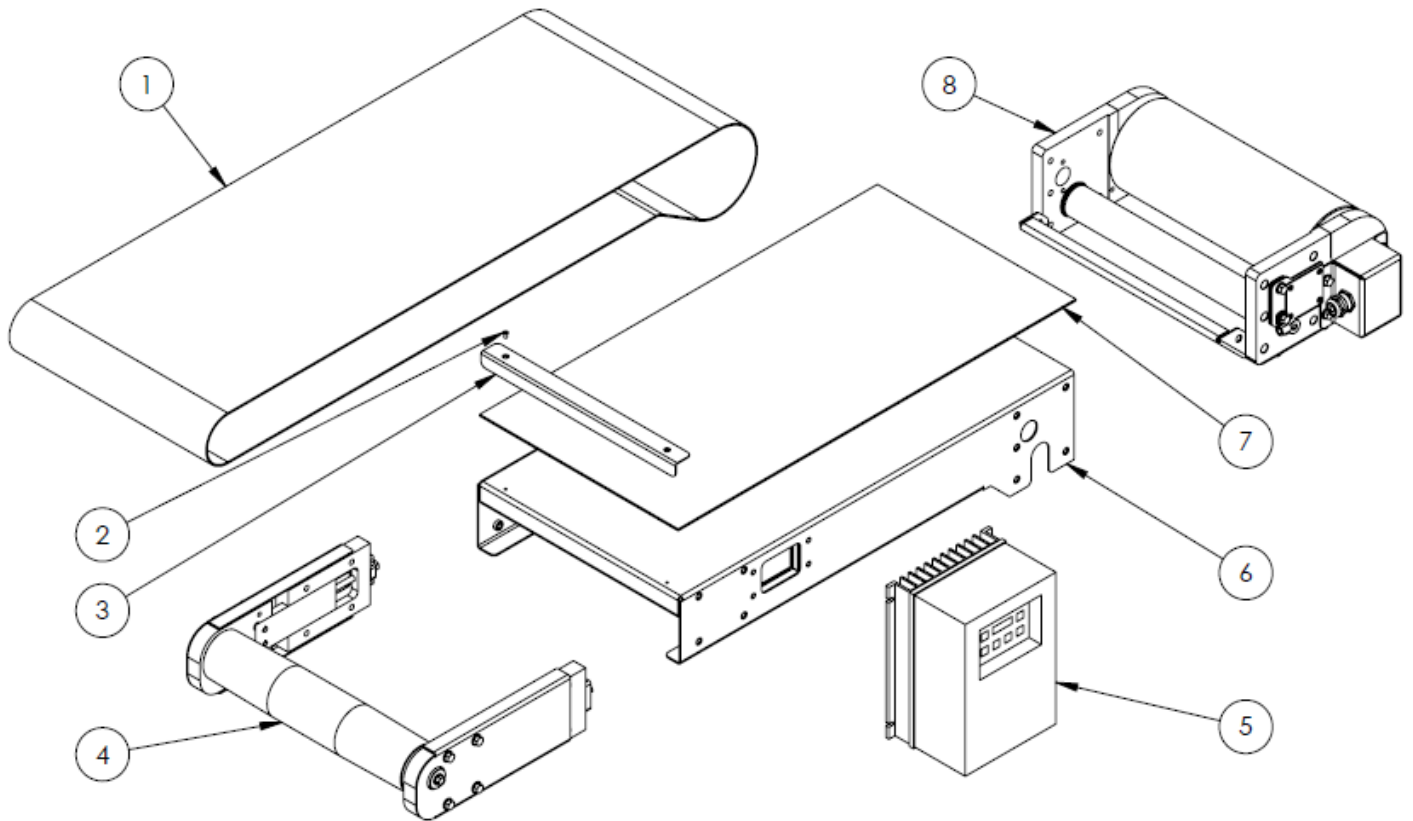

Figure 5. MISC. COMPONENTS



GENERAL INFORMATION

PAX PRODUCTS, INC.
P.O. BOX 257
5097 MONROE RD.
CELINA, OHIO 45822
PH. (419) 586-6948
(800) 733-6930
FAX (419) 586-6932

YOUR REGIONAL SALES REPRESENTATIVE IS:

COMPANY: _____
ADDRESS: _____

PHONE: _____
FAX: _____